

Installation and Safety Instructions

Outdoor Pendant Light Fitting

Safety Warnings

- It is recommended that this light be installed by a qualified electrician in accordance with current IEE Wiring Regulations and Building Regulations (Part P).
- This product is suitable for connection to a 240v~50Hz supply.
- This light fitting should be connected to a circuit with a 30mA RCD fitted, and it is recommended that you use H05RN-F specification cable (not supplied) which is an outdoor grade, rubber sheathed cable. The mains supply cable must have a minimum cross sectional area of 1.0mm².
- This fitting is a Class I, Earthed product, and **must be** connected to Earth.
- Switch off the mains supply and remove the appropriate fuse or switch off the appropriate circuit breaker before commencing installation.
- Do not install a bulb with a greater wattage or different shape than specified on the label.
- If any modification is made it will invalidate the warranty and may render the product unsafe.
- An electrician must be consulted if in any doubt about your own competency or meaning of "RCD".

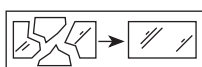

This product is rated at IP44. It is not suitable for location in or near a marine or sea environment. The shade must be replaced immediately should it become cracked or damaged. This fitting must not be used without the shade in place. If in doubt, please consult your retailer.

Care Information

- Allow 10 minutes to cool before replacing, adjusting or cleaning.
- Clean with a dry cloth only. Do not use liquid or abrasive cleaners on this product, and **do not clean with a pressure washer**.

Assembly/ User Instructions

Before you start

Check the packaging and make sure that you have all the required parts. Follow each assembly step in order to prevent incorrect assembly. Ensure that the product is fully assembled as illustrated before use.

The Light pack contains:

Light fitting.
Terminal connection block(s).
Fixing pack.

The following tools may be required:

Selection of cross and flat head screwdrivers.
Electric drill and assorted drill bits.
Wire strippers.
Electrical insulation tape.

These assembly diagrams are intended as a guide – if in doubt consult a qualified electrician.

1. Decide on the position of the light fitting, or remove existing light fitting. Take a note of the position of the electrical connections. Ensure there is a solid mounting surface, preferably a wooden joist or joist bridge to support the weight of the light fitting.
2. Run cable (not supplied) from mains electrical supply to selected site, ensuring it is adequately protected through the full length of the cable run. Except where installed in a conduit or duct which provides equivalent protection against mechanical damage, a cable buried in the ground shall incorporate an earthed armour or metal sheath or both, suitable for use as a protective conductor, or be of insulated concentric construction. Buried cables shall be marked by cable covers or a suitable marking tape. Buried conduits and ducts shall be suitably identified. Buried cables, conduits and ducts shall be at a sufficient depth to avoid being damaged by any reasonably foreseeable disturbance of the ground.
3. Remove the two finials (4) and retain for later re-use. Use the plastic mounting plate as a template to mark the screw holes. Pass the supply cable through the rubber grommet in the mounting plate, ensuring that

Assembly/ User Instructions Continued

- the hexagonal screws are located in the back of the mounting plate, and secure the mounting plate with suitable screws and secure to the ceiling with appropriate screw fixings (1&2).
- Support your fitting and connect the house wiring to the terminal block (3). **NOTE: This is a Class I fitting and must be earthed.** See wiring diagram for details.
 - Secure ceiling cup to mounting plate with the finials removed in Point 3, ensuring no wires are trapped, and the rubber seal is fitted correctly to maintain the ingress protection.
 - Fit the bulb (5). **NOTE: Never fit bulbs of a higher wattage than those specified on the label (as these may cause overheating and damage the fitting).**
 - Fit threaded rods (6) into holes either side of the lid, and secure lid to shade with nuts provided.
 - Turn on the power and test.

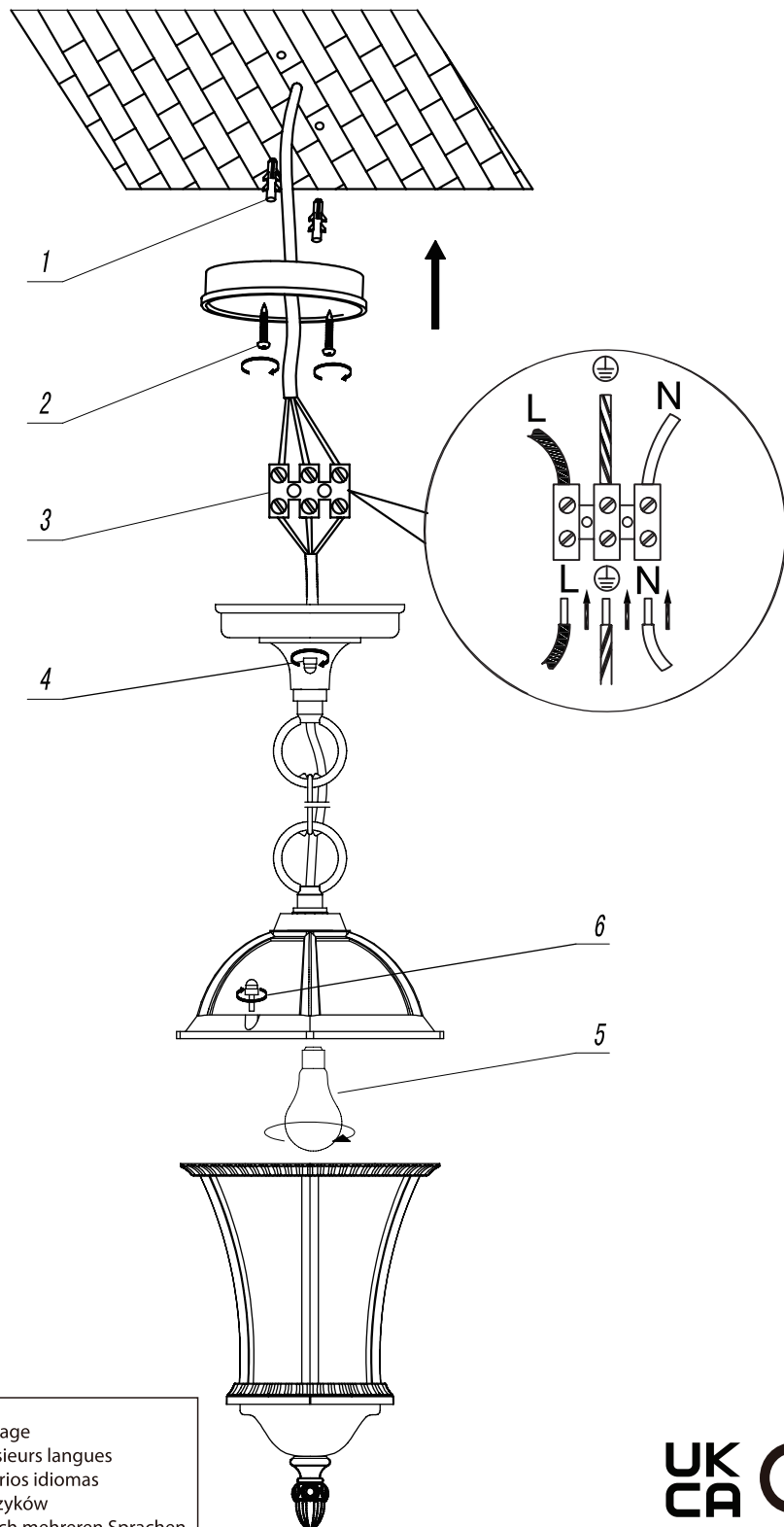

- EN Scan QR code for multi-language
- FR Scannez le code QR pour plusieurs langues
- ES Escanee el código QR para varios idiomas
- PL Zeskanuj kod QR dla wielu języków
- DE Scannen Sie den QR-Code nach mehreren Sprachen
- IT Scansiona il codice QR per multilingua



UK Manufacturer: BH17 7BY
EU Manufacturer: Brilliant AG,
Brillantstrasse 1, D-27442 Gnarrenburg